

AUDAX

LA PASSION DU HAUT-PARLEUR

PR300M0

WOOFER

1008001

12" - PAPER CONE DRIVER - 300 mm**PROFESSIONAL LINE**

Low resonance frequency - 20 Hz -
Zamak die cast chassis
Exponential paper cone
Foam suspension
Kapton voice coil former (48 mm Ø)
Flat copper wire
Gold plated binding post

Fréquence de résonance basse - 20 Hz -
Châssis Zamak moulé
Cône papier profil exponentiel
Suspension mousse
Bobine sur support Kapton (Ø 48 mm)
Fil cuivre plat sur chant
Bornes plaquées or



This 12" woofer has been designed to offer long excursion capabilities (large foam half-roll suspension) coupled with high efficiency and good power handling. The low resonance and long edgewound flat copper wire voice coil makes it suited for subwoofer applications. The gold plated binding posts fitted onto the die cast chassis offer the possibility of using large diameter cables. The "suggested applications" charts indicate various driver loads. The response curves shown on the diagram indicate the predicted low end response of the driver in the suggested box volume (Vb) with suggested port (Dp-Lp).

Ce haut-parleur de 300 mm a été développé pour offrir la possibilité de grandes élancements (large suspension 1/2 rouleau en mousse) associée à une bonne tenue en puissance et un rendement élevé. Sa résonance très basse ainsi qu'une bobine longue sur support Kapton en fil de cuivre plat sur chant le destinent à une utilisation en grave ou subwoofer. Son châssis Zamak moulé est équipé de borniers plaqués or permettant l'utilisation de câbles de forte section. Le tableau "Suggested applications" indique différents types de charge. Les courbes publiées correspondent à la réponse dans le grave pour un volume (Vb) et une dimension d'évent donnée (Dp-Lp).

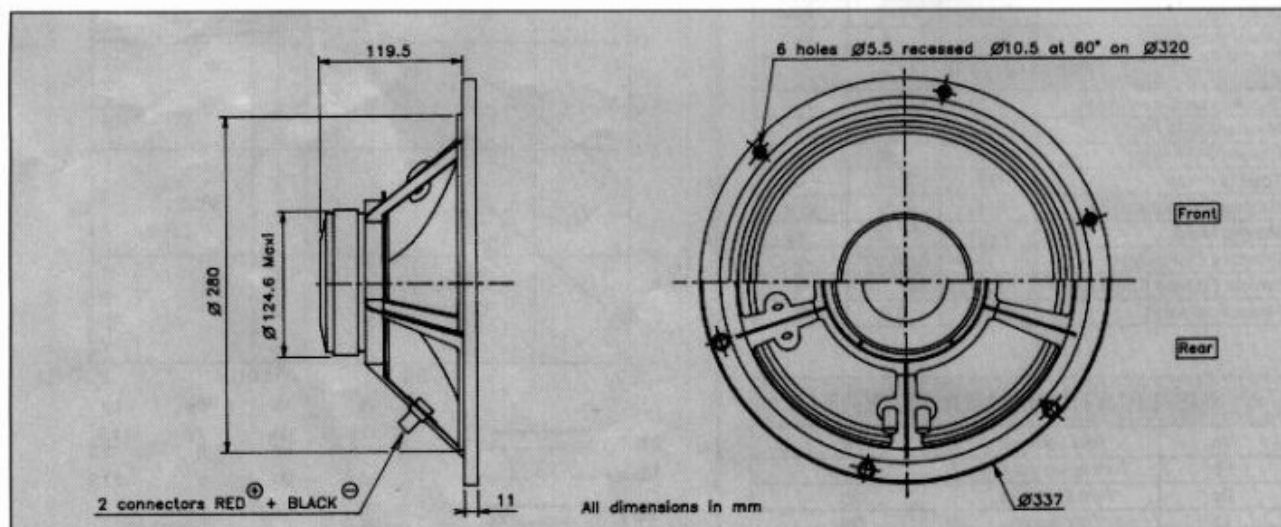

RESPONSE CURVE
refer to page 16

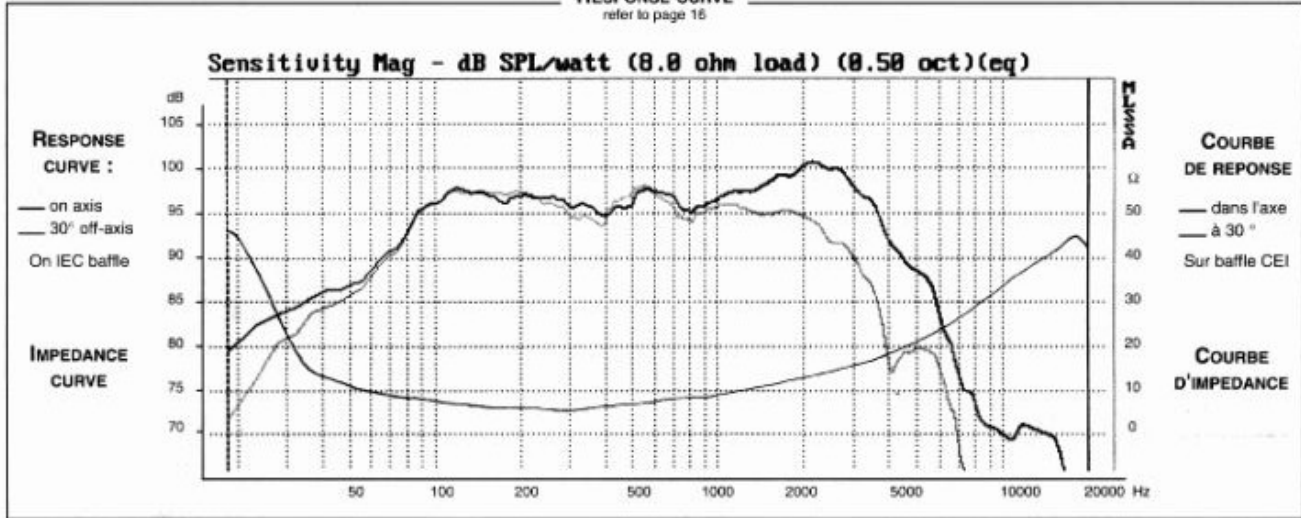

SPECIFICATIONS

Technical Characteristics	Symbol	Value	Units
PRIMARY APPLICATION			
Nominal Impedance	Z	8	Ω
Resonance Frequency	Fs	17	Hz
Nominal Power Handling	P	100	W
Sensitivity	E	97	dB

VOICE COIL			
Voice coil diameter	∅	48	mm
Minimum Impedance	Zmin	6,4	Ω
DC Resistance	Re	5,7	Ω
Voice Coil Inductance	Lbm	0,42	mH
Voice coil Length	h	14,8	mm
Former	-	Kapton	-
Number of layers	n	1	-

MAGNET			
Magnet dimensions	∅ x h	120 x 20	mm
Magnet weight	m	0,88	kg
Flux density	B	1	T
Force factor	BL	8,4	NA ⁻¹
Height of magnetic gap	He	6	mm
Stray flux	Fmag	-	Am ⁻¹
Linear excursion	Xmax	±4,4	mm

PARAMETERS			
Suspension Compliance	Cms	2,64.10 ⁻¹	mN ⁻¹
Mechanical Q Factor	Qms	3,55	-
Electrical Q Factor	Qes	0,28	-
Total Q Factor	Qts	0,26	-
Mechanical Resistance	Rms	1	kg s ⁻¹
Moving Mass	Mms	33.10 ⁻³	kg
Effective Piston Area	S	5,21.10 ⁻²	m ²
Volume Equivalent of Air at Cas	Vas	1012.10 ⁻³	m ³
Mass of speaker	M	3,2	kg

APPLICATION PARAMETERS

Symbol	Description	Unit
Vb	Box volume	dm ³
Fb	Tuning frequency	Hz
Dp	Port diameter	cm
Lp	Port length	cm

IMPULSE RESPONSE **WATERFALL**
refer to page 16

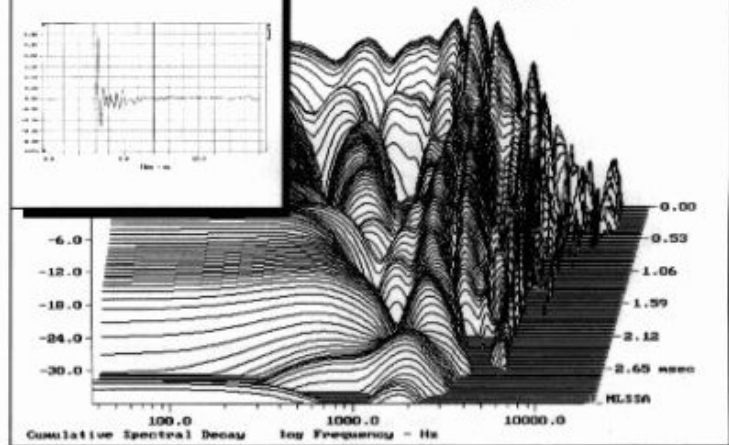

SUGGESTED APPLICATIONS
refer to page 8 to 13

